

WIND-FLEX

SPRING-RELEASE POLE BANNER BRACKETS

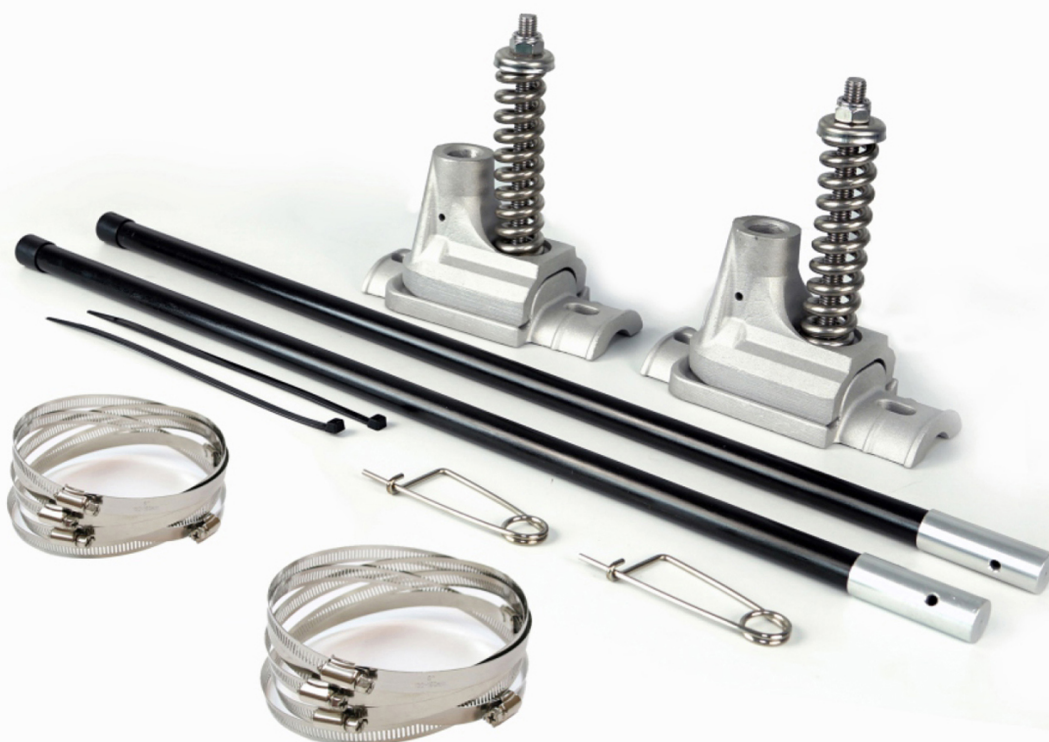

INSTALLATION GUIDE

Congratulations! You've chosen Wind-Flex, Before you begin installation. Carefully read this page to: familiarize yourself with the components of a Wind-Flex kit, gather the additional tools needed for proper installation, and ensure you've purchased the correct banding for your project.

STANDARD

Wind-Flex KIT

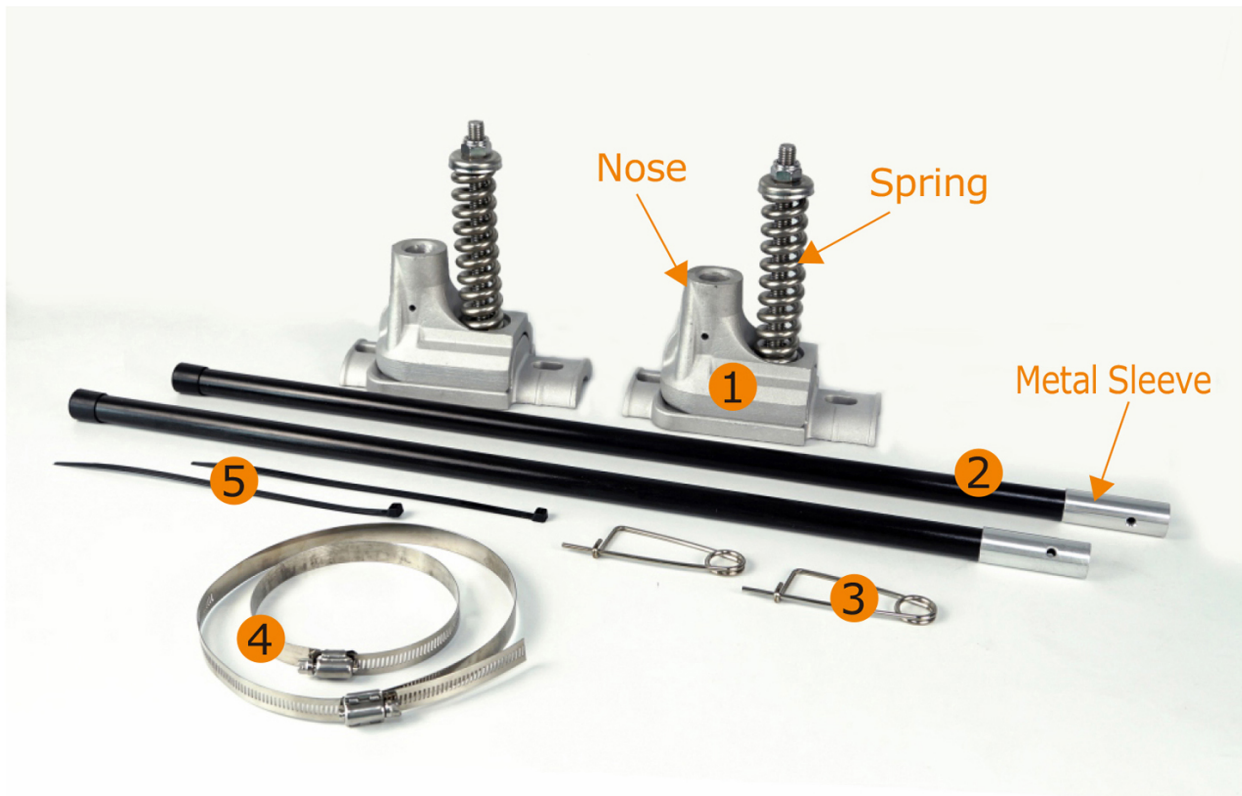

- 1 Banner Bracket (2)
- 2 Fiberglass arm (2)
- 3 Pin (2)
- 4 Standard Banding (6)
- 5 Zip tie (2)

ADDITIONAL TOOLS REQUIRED FOR INSTALLATION

- Lift truck
- Electric screwdriver (standard banding)
- Banding tool (heavy duty banding only)
- Tin snips
- Plastic snips
- Duct tape

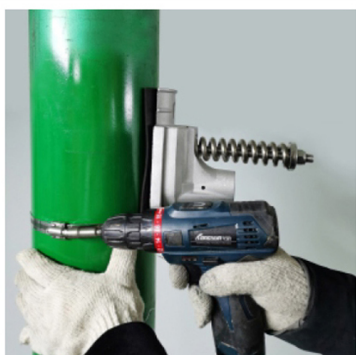

Figure 1

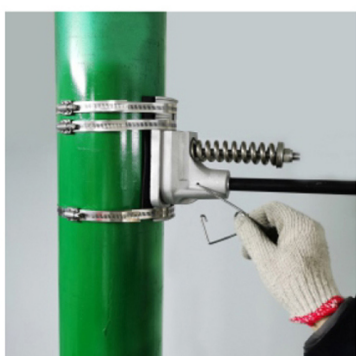

Figure 2



Figure 3

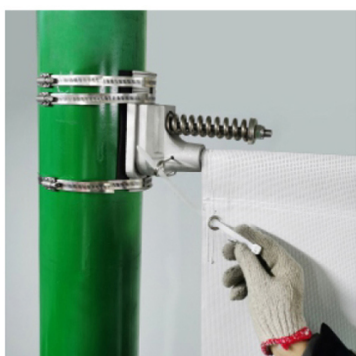

Figure 4

TOP BRACKET (STANDARD BANDING)

Step 1: Secure Banding Following the instructions appropriate for your banding, position and attach bracket to pole, using duct tape to temporarily secure bracket while metal bands are positioned (see Figure 1). Secure metal bands with screwdriver or banding tool and remove any duct tape. Reminder: Spring on top!

Step 2: Install Arm and Secure Insert fiberglass arm through top pole pocket of banner and insert end of arm with the metal sleeve into the nose of the bracket.

Step 3: Secure With Pin and Zip Tie Insert pin through nose and fiberglass arm (see Figure 2). Finish with zip tie through grommet (see Figure 3).

Step 4: Complete Tighten banding. Clip excess banding and zip tie with snips (see Figure 4).

REPOSITION

Step 5: Position yourself down the pole to approximate bottom bracket position.

BOTTOM BRACKET

Step 6: Secure Banner to Arm At this point, your banner will be attached to the top bracket only and hanging downwards. Insert fiberglass arm through bottom pole pocket of banner with the metal sleeve inserted into the nose of the bracket. Note: The bottom bracket is not yet attached to pole at this point.

Step 7: Secure with Pin Insert the pin through nose and fiberglass arm. The banner is now fully extended and attached to the bracket. The bracket is now ready to be installed on the pole.

Step 8: Attach to Pole Push bottom bracket against pole — spring on bottom — and install both top bands.

Step 9: Bottom Band Push bottom edge of bracket against the pole and install bottom band.

Step 10: Complete Finish with zip tie through grommet. Trim ends of the zip tie and banding.

The Wind-Flex is easy to install, move and adjust. Be sure to read the step-by-step instructions — paying close attention to the helpful Recommendations section — in full before attempting installation.

HELPFUL RECOMMENDATIONS

- We recommend a “top-to-bottom” approach. Install the top bracket first, bottom bracket second.
- It is highly recommended that you install the banner at the same time you install the brackets. Installing the brackets prior to installation the banner will likely result in necessary adjustments and incorrect measurements.
- Recommended install height: Minimum of 15' from the ground to bottom of banner (for parking lots and street locations).
- Spring position is important. Remember: Top bracket, spring on top. Bottom bracket, spring on bottom.
- If using standard banding, use 3 bands per bracket — 2 on the spring end, 1 on the other. Heavy banding uses 2 bands — 1 on the spring end, 1 on the other.

MAINTENANCE

With regular maintenance, your Banner Bracket will last for years, protecting banners and reducing light pole liabilities. We recommend the following maintenance schedule:

- Return to the install site within 2-4 weeks of the first install to tighten bands if necessary.
- Check on banding once a quarter and/or after high wind storms. It may be necessary to tighten or replace banding from time to time.
- Note: All banding of any kind, from any company, requires maintenance. Heavy banding costs more up front but will reduce maintenance costs in the long run.